

HUSK ASPIRATOR WITH INBUILT BLOWER



PERFECT
AN ISO 9001 : 2008 CERTIFIED COMPANY

WORKING PRINCIPLE



HIB5

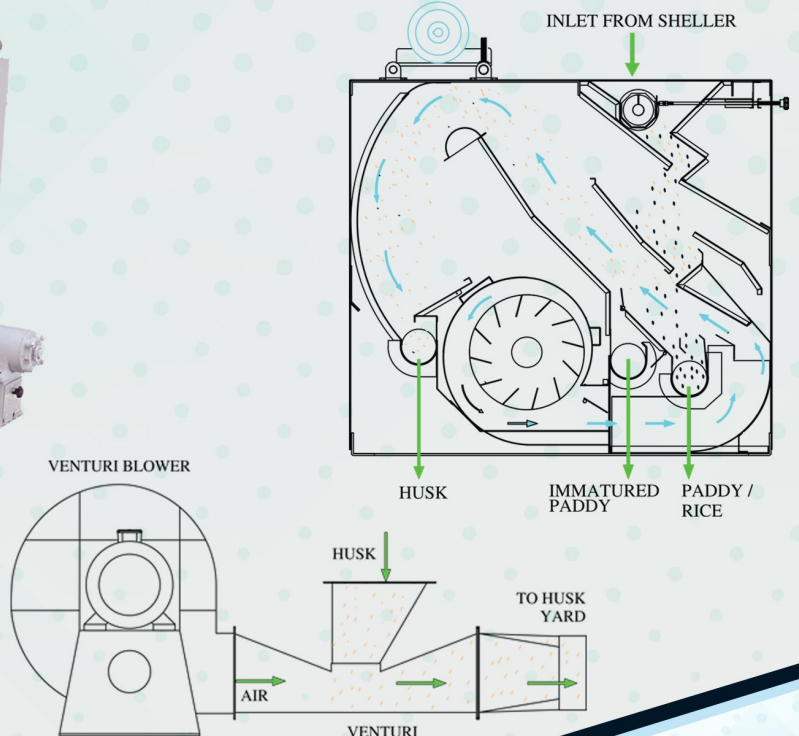

Perfect's Husk Aspirator with Inbuilt Blower is specially designed to separate husk / Immature grain from shelled paddy.

Suitable for:

- ❖ All types of grains

Salient Features

- ❖ In built blower requires no maintenance of impeller
- ❖ Accurate separation of Husk from mixture
- ❖ Conveyor for uniform feeding
- ❖ Stainless steel impellers and baffles for long life

Product Model	Capacity of Shelled rice, TPH	Power, HP	Overall Dimensions in MM (LXWXH)	Weight in Kgs (App.)
HIB5	4 - 5	5x1440	1500X1850X1600	900



PERFECT EQUIPMENTS

AN ISO 9001 : 2008 CERTIFIED COMPANY

Channel Partner :

- H.O: No.7, Multi Industrial Estate, Gerugambakkam, Chennai-600 122.
- Ph: 044-2382 0042, 2382 0512
- Email : perfectmrm@gmail.com, info@perfectequipments.in
- Web: www.perfectequipments.in, www.ricemillmachinery.in

- Factory : S.No.228/1A, 1B, Mettupalayam Road, Banrutti Village, Sriperumbudur TK., Kanchipuram Dt. Pin: 631 604.
- Ph: 94459 08800, 11, 22, 33.

We reserve the right to correct the specification without any notice.

CUSTOMER SATISFACTION IS OUR MOTTO